

TGKX.205A - ROOF DECK CONSTRUCTIONS

Design/System/Construction/Assembly Usage Disclaimer

- Authorities Having Jurisdiction should be consulted in all cases as to the particular requirements covering the installation and use of UL Certified products, equipment, system, devices, and materials.
- Authorities Having Jurisdiction should be consulted before construction.
- Fire resistance assemblies and products are developed by the design submitter and have been investigated by UL for compliance with applicable requirements. The published information cannot always address every construction nuance encountered in the field.
- When field issues arise, it is recommended the first contact for assistance be the technical service staff provided by the product manufacturer noted for the design. Users of fire resistance assemblies are advised to consult the general Guide Information for each product category and each group of assemblies. The Guide Information includes specifics concerning alternate materials and alternate methods of construction.
- Only products which bear UL's Mark are considered Certified.

Roof Deck Constructions

See General Information for Roof Deck Constructions

Construction No. 205A

March 19, 2015

**Uplift — Class 90 or 30 (See Item No. 1)
Fire Not Investigated**

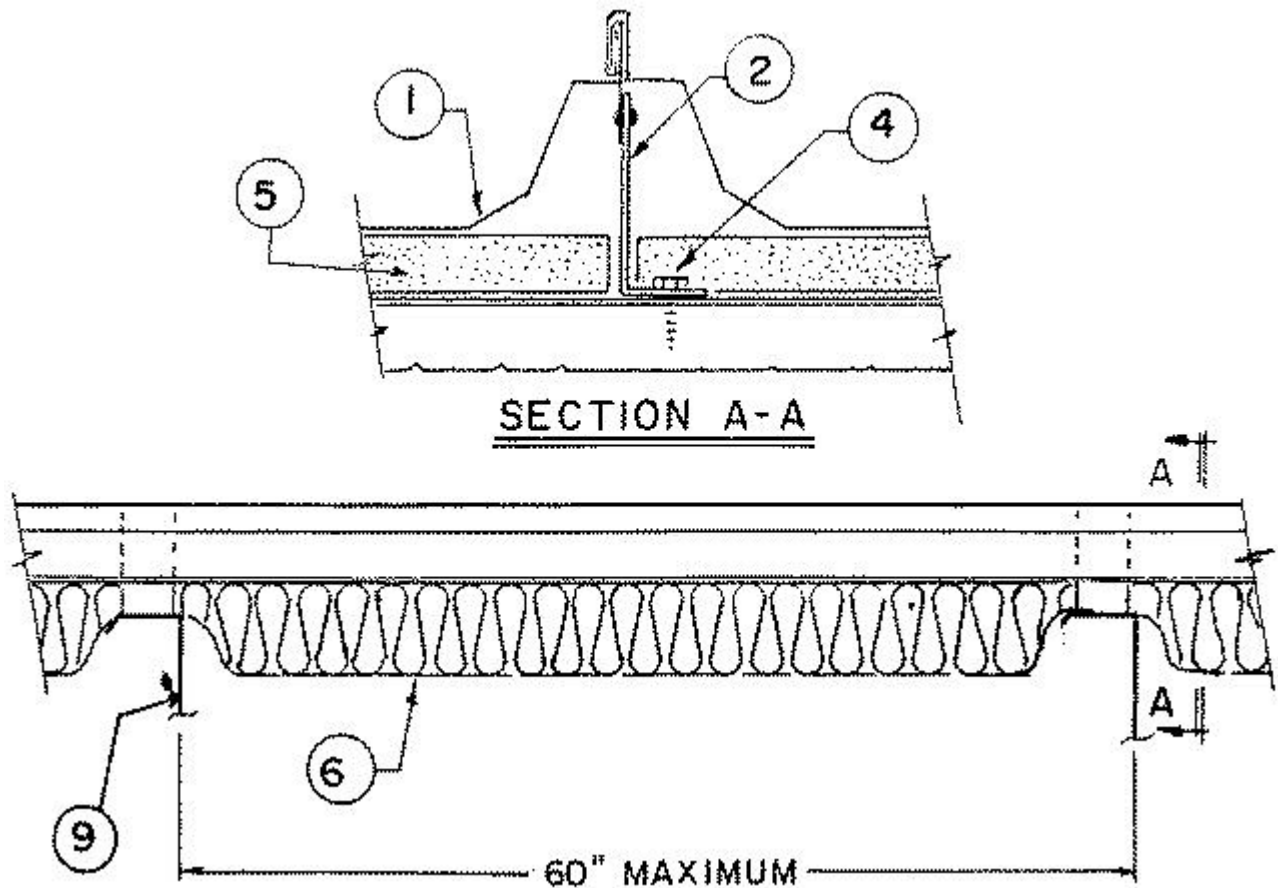

1. **Metal Roof Deck Panels*** — Maximum width 24 in., height at female rib 2-13/16 in. For Class 90, 24 MSG min coated steel. For Class 30, 26 MSG min coated steel. Panels continuous over two or more spans. End laps to occur adjacent to purlin with panels overlapped 3 in. A line of sealant may be used at panel end laps and side joints, adjacent panels may be seamed with electric seamer with seaming operation to include roof deck fasteners (Item 2). Male/female side laps shall remain interlocked and fully engaged after seaming.

A & S BUILDING SYSTEMS L P (View Classification) — "Ultra Dek".

B C STEEL BUILDINGS INC (View Classification) — "BCL-SD"

CENTRAL STATES MFG INC (View Classification) — "Central-Loc"

CENTRAL TEXAS METAL ROLLFORMING INC (View Classification) — "Shurloc 300"

CHIEF INDUSTRIES INC (View Classification) — "STC"

CLEBURNE SHEET METAL (View Classification) — "Dominator 24"

CORLE BUILDING SYSTEMS INC (View Classification) — "Corle Snap Seal"

KIRBY BUILDING SYSTEMS INC (View Classification) — "KLS 2100"

MBCI (View Classification) — "Ultra-Dek"

MESCO METAL BUILDINGS (View Classification) — "Ultra-Dek"

PINNACLE STRUCTURES INC (View Classification) — "PINNACLE U-DEK"

NCI BUILDING SYSTEMS L P (View Classification) — "Ultra-Dek"

TEXAS BUILDING AND ROOFING SUPPLIES INC — "Standing Seam" Panel

UNITED STRUCTURES OF AMERICA INC (View Classification) — "Guardian I", "Guardian II" (seamed only).

WHIRLWIND STEEL BUILDINGS INC (View Classification) — "Super-Seam II"

2. **Roof Deck Fasteners*** — (Panel Clips) — Clip used with an upper tab clip formed to engage the metal roof deck panel rib (Item 1). Height of the clip to be 3-3/8 in. when no thermal spacer (Item 5) is used, and 4-3/8 in. when a thermal spacer is used. Clips are spaced 5 ft OC max along length of panels, located at the panel sides with three guide holes in the bottom to accommodate screw fasteners (Item 4).

BUILDING PRODUCTS DEVELOPMENT INC (View Classification) — "NC34503", "NC34504"

CHIEF INDUSTRIES INC (View Classification) — "STC Sliding Clip"

KIRBY BUILDING SYSTEMS INC (View Classification) — "Kirbylok 2000 Clip" or "Kirbylok 2000 Clip II".

NCI BUILDING SYSTEMS L P (View Classification) — "Ultra-Dek Articulating Clip" or "Ultra-Dek Floating Clip" or "Ultra-Dek Sliding Clip" or "Ultra-Dek Fixed Clip."

2A. **Roof Deck Fasteners* — (Panel Clips)** — (Not shown) — Two part assembly. Base 4-1/4 in. wide, max height 3.3 in. Fabricated from No. 17 MSG min thick coated steel. Tab 3 in. wide at top, approximately 2 in. high. Parts formed to interlock. Max assembled height approximately 4-1/2 in. Two Fasteners (Item 4) used per clip.

BUILDING RESEARCH SYSTEMS INC (View Classification) — "Challenger 400 Series Clip"

3. **Building Units*** — (Optional) (Not shown) — Translucent, reinforced plastic panels. Nom thickness, 1/16 in., formed to the same configuration as the metal roof deck panels, with a metal reinforcement cut from a Classified metal roof deck panel ("Ultra-Dek"). Metal reinforcement attached to translucent, reinforced plastic side segments with aluminum pop rivets. Panels continuous over two spans.

KIRBY BUILDING SYSTEMS INC (View Classification) — "Kirbylok 2000"

NCI BUILDING SYSTEMS L P (View Classification) — "Ultra-Dek Light Transmitting Panel"

UNITED STRUCTURES OF AMERICA INC (View Classification) — "Guardian I Skylight"

4. **Fasteners** — (Screws) — Screws used to attach the panel clips to purlin to be one (1) 1/4-14 by 1-1/4 in. long, self-drilling, 3/8 in. hex-head, plated steel screws with a separate 5/8 in. O.D. neoprene washer. If no thermal spacer (Item 5) is used, the screws may be 1 in. long. Screws used at end lap are to be 1 in. long and same type as panel clip to purlin attachment. Five (5) fasteners are to be used in the flat section of the end lap panel with the first fastener located 3 in. from either rib, and then spaced in a 3-6-6-3 in. pattern. An additional fastener is to be located at the second slanted segment of the rib on both sides of the end lap panel, and one additional fastener located at the first slanted segment on both sides of one rib. Fasteners used with alternate 16 MSG min thick coated steel upper section to be No. 14 by 1 in. long self-tapping fastener. First fastener located 3/8 in. from first slanted segment in a 4-5-1/2-5-1/2-4 in. pattern. One additional fastener located 1/2 in. from first slanted segment on opposite side of same rib where first fastener is located.

Screws used to attach the panel clip to purlin when an optional Light Transmitting Panel is used are to be two (2) No. 12 by 1-1/2 in. long, self-drilling, 3/8 in. hex-head, plated steel screws with a separate 5/8 in. O.D. neoprene washer. If no thermal spacer (Item 5) is used, these screws may be 1 in. long. Screws used to fasten optional Light Transmitting Panel backing plate (Item 8) to be the same type as those used at the panel end lap. These screws are located at second slanted segment adjacent to rib with three screws spaced 1-1/2 in. O.C. and at first slanted segment adjacent to rib with two screws spaced 3 in. O.C.

5. **Thermal Spacer** — (Optional) — Polystyrene, 1 in. max thickness, 3 in. wide, cut to fit between panel clips.

6. **Insulation** — (Optional) — Any compressible blanket insulation, 6 in. max thickness before compression with 3/8 in. thermal spacers or 5 in. max thickness insulation before compression with max 1 in. thermal spacers when installed between thermal spacer (Item 5) and purlin (Item 9).

7. **End-Lap Plate Assembly** — (Not shown) — Used at panel end laps consisting of a lower section, 5-5/8 in. wide, with a 1/8 in. leg and formed to the general profile of the panel and having four 1 in. wide by 3/4 in. long tabs for sliding over the end panel. Upper section to be 2 in. wide and also formed to the general profile of the panel. Both parts to have ribs formed with reinforcement. Both parts min 18 MSG thick coated steel. Alternate 16 MSG min thick coated steel upper section 1-1/2 in. wide formed to the general profile of the panel with one end formed to fit over a side rib. Six 5/16 in. diam. guide holes located in the flat area only.

8. **Light Transmitting Panel Backing Plate** — (Optional) (Not shown) — When Light Transmitting Panel is used, backing plate required. Min 18 MSG galv steel, 6 in. wide with two vertical legs on both sides and formed to the configuration of metal roof deck panel (Item 1). Located over purlin and offers support to continuous segment building unit (Item 3).

9. **Purlin** — Min No. 16 MSG steel (55,000 psi min yield strength).

Refer to General Information, Roof Deck Construction, (Roofing Materials and Systems Directory) for Items Not Evaluated.

*** Indicates such products shall bear the UL or cUL Certification Mark for jurisdictions employing the UL or cUL Certification (such as Canada), respectively.**

Last Updated on 2015-03-19

The appearance of a company's name or product in this database does not in itself assure that products so identified have been manufactured under UL's Follow-Up Service. Only those products bearing the UL Mark should be considered to be Certified and covered under UL's Follow-Up Service. Always look for the Mark on the product.

UL permits the reproduction of the material contained in the Online Certification Directory subject to the following conditions: 1. The Guide Information, Assemblies, Constructions, Designs, Systems, and/or Certifications (files) must be presented in their entirety and in a non-misleading manner, without any manipulation of the data (or drawings). 2. The statement "Reprinted from the Online Certifications Directory with permission from UL" must appear adjacent to the extracted material. In addition, the reprinted material must include a copyright notice in the following format: "© 2019 UL LLC"